

Peregrine 3041



The Peregrine 3041 is a high performance imaging camera for use in applications that demand extreme sensitivity under low light conditions. The camera is based upon the CCD 3041, a scientific grade 2k x 2k imager, available in either front or back-illuminated versions. The camera boasts a low noise four-port readout architecture for superior speed and sensitivity. A true dual digitizer design provides optimal signal fidelity in both slow scan and fast focus operation modes. Dark current is effectively eliminated with deep thermoelectric cooling to -30°C . Linear, 16-bit dynamic range and sophisticated features such as software control over binning and gain make the Peregrine the ultimate instrument in scientific optical imaging. The

camera is packaged in a compact and rugged housing for easy integration into OEM instrumentation. Lenses are easily mounted via the included F-mount adapter. Software drivers are available for MaxImDL and MicroCCD software packages. Software developer's kit available upon request.

Features

Benefits

2k x 2k sensor	High resolution (4 Megapixel)
31 mm x 31 mm imaging area	High Optical Throughput (large etendue)
Back-illuminated CCD option	Highest quantum efficiency
Four-port readout	Optimal design for speed and sensitivity
Dual Digitizer	Separate, optimized readout channels for lowest noise and highest speed
Deep Cooling & Low Noise Readout	Negligible noise = high sensitivity
Software Gain & Binning	Tailor the detector to your imaging requirements
Linear 16-bit dynamic range	Scientific precision and accuracy
Software-controlled binning & windowing	Optimize speed versus resolution
Drivers for MaxImDL and MicroCCD software	Powerful software for Astronomy and Microscopy applications



Peregrine 3041

Specifications

Sensor	CCD 3041, front or back-illuminated, scientific grade 1		
Type	2048 x 2048 pixels		
Resolution	15 μm x 15 μm		
Pixel Size	30.72 mm x 30.72 mm		
Image Area			
	Minimum	Typical	Maximum
Read Noise			
500 kHz		8 e ⁻	10 e ⁻
3 MHz		25 e ⁻	30 e ⁻
Full Well Capacity			
Single Pixel	80 ke ⁻	100 ke ⁻	
Output Register	700 ke ⁻	800 ke ⁻	
Gain		1.2 e ⁻ /ADU (nominal)	
Linearity		< 1%	
Dark Current (-30°C)		0.5 e ⁻ /pix/sec (F/I) 1.0 e ⁻ /pix/sec (B/I)	1.0 e ⁻ /pix/sec (F/I) 2.0 e ⁻ /pix/sec (B/I)
Cooling	-30° C, Thermoelectric w/forced air		
Output Ports	4 low noise amplifiers		
Readout Rate			
12 MHz	4 ports x 3 MHz		
2 MHz	4 ports x 500 kHz		
Binning			
Shutter	Integral 65mm mechanical shutter, 100 ms open time		
ADC Dynamic Range	16-bit		
Vertical Shift Speed	120 μsec		
Operating Range	15°C to 30°C; 40% to 75% relative humidity (non-condensing)		
Interface	USB 2.0		
I/O Triggers	External Trigger In, Exposure Out		
Dimensions (H x W x L)	3.7 in. x 3.7 in. x 6.9 in. (94 mm x 94 mm x 175 mm)		
Camera Weight	7.5 pounds (3.4 kg)		

*Note: All Specifications measured in 1x1 (full image) mode unless stated otherwise. Subject to change without notice.

Mechanical Drawing

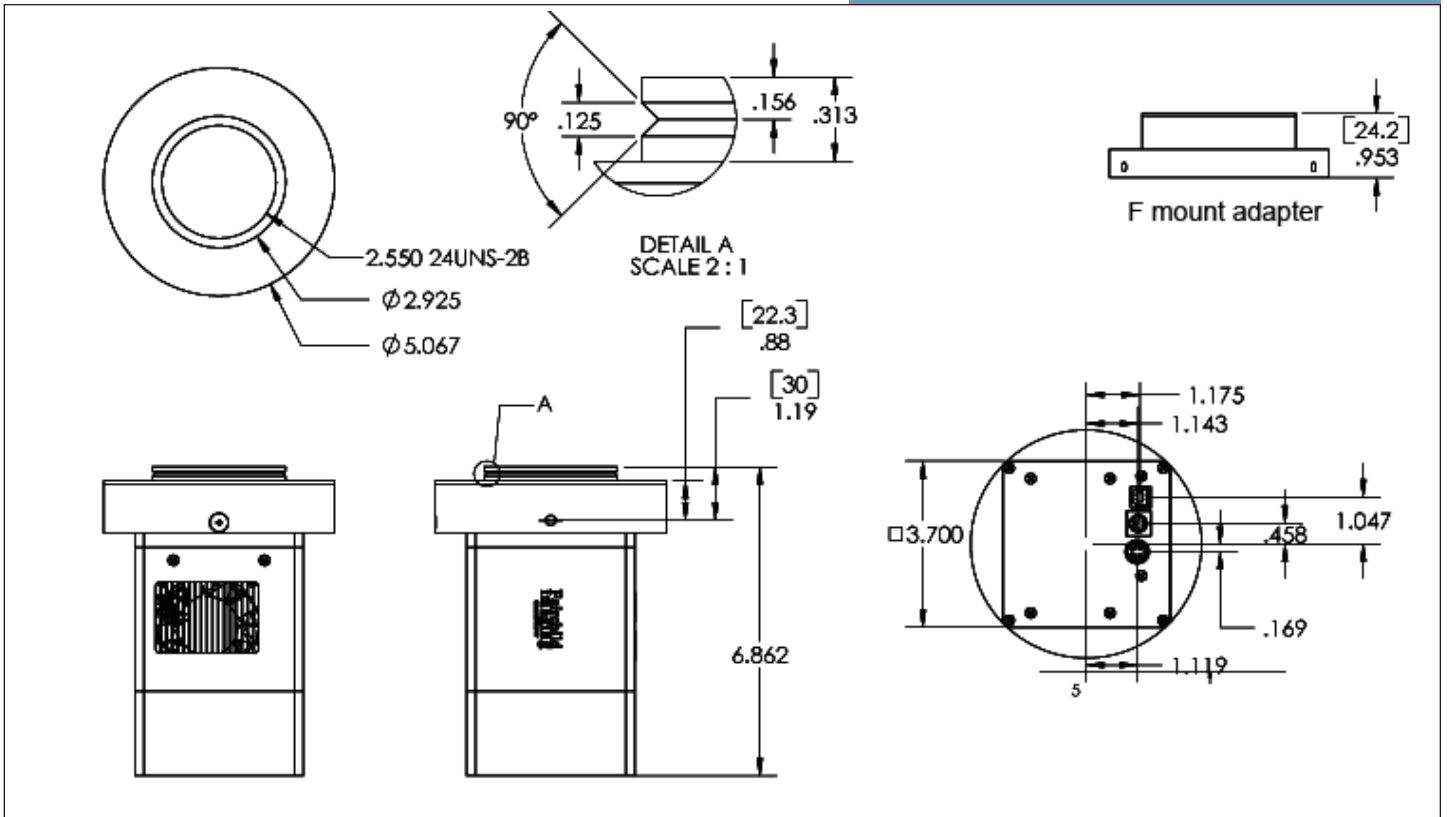

Readout Rates

	1 X 1	2 X 2	4 X 4
Readout Time	0.78 sec	0.48 sec	0.29 sec
Frame Rate	1.3 fps	2.1 fps	3.4 fps

Note: Measured with 10 msec exposure, 3MHz readout. Actual results may vary depending upon your experimental conditions.

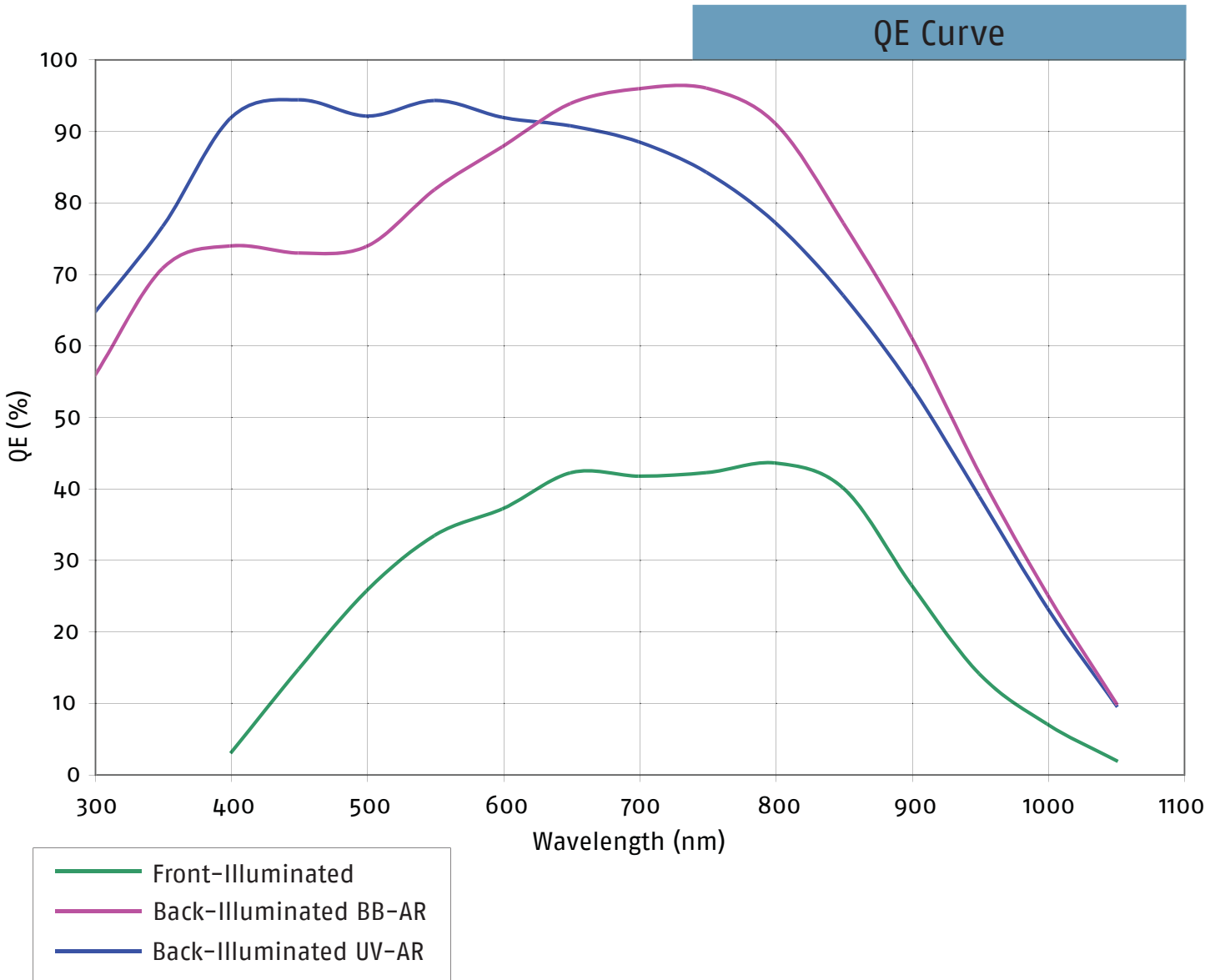

Fairchild Imaging certifies that its products are fully inspected and tested at the factory prior to shipment, and that they conform to the stated specifications.

This product is designed, manufactured, and distributed utilizing the ISO 9001:2008 Business Management System.