

Condor 486:90



The Condor™ 486:90 is an ultra-sensitive, fiber-optic coupled camera for use in x-ray imaging applications that demand a large field of view and high throughput. The camera is based upon a state-of-the-art, scientific grade, 4k x 4k sensor. At more than 60 x 60 mm², the sensor is the largest commercially available CCD and when coupled to a 1:1 imaging fiber-optic, it delivers unsurpassed optical throughput. The camera boasts a low-noise, dual-speed, four-port readout architecture for superior speed and sensitivity. Dark current is virtually eliminated with deep thermoelectric cooling to -60°C. Hard metal seals assure a reliable vacuum and continuous maintenance-free operation. Linear, 16-bit dynamic range and sophisticated features such as anti-blooming control and software

control over binning and gain make the Condor™ the ultimate instrument for scientific x-ray imaging. The camera comes standard with a beryllium window for transmitting x-rays while blocking visible light. A range of x-ray phosphors can be selected for your particular application.

Features

Benefits

4k x 4k sensor	High resolution (16 Megapixel)
60 mm x 60 mm CCD image area	Large field of view
1:1 straight fiber-optic faceplate	Highest throughput, no taper distortion
Four-port readout	Optimal design for speed and sensitivity
Deep thermoelectric cooling	Minimize dark noise
High-performance low-noise electronics	Minimize readout noise
Linear 16-bit dynamic range	Scientific precision and accuracy
Software-controlled binning & windowing	Optimize speed versus resolution
Plug-in for ImagePro Plus software	Data acquisition and analysis



Condor 486:90

Specifications

Sensor	16MP CCD, scientific grade 1, front-illuminated		
Type	4096 x 4096 pixels		
Resolution	15 μm x 15 μm		
Pixel Size	61.44 mm x 61.44 mm		
Image Area	1:1 fiber-optic faceplate (90 mm diagonal)		
Fiber Optic Phosphor	Gadolinium Oxysulfide (Gd ₂ O ₂ S) – Custom phosphors available		
Read Noise	Minimum	Typical	Maximum
	1 MHz	10 e ⁻	12 e ⁻
250 kHz	5 e ⁻	7 e ⁻	
Full Well Capacity			
Single Pixel	80 ke ⁻	100 ke ⁻	
Output Register	700 ke ⁻	800 ke ⁻	
Gain		1.5 e ⁻ /ADU (nominal)	
Linearity		< 1%	
Dark Current (-60 °C)		0.005 e ⁻ /pix/sec	0.01 e ⁻ /pix/sec
Cooling	-60°C, Thermoelectric w/chilled water		
Output Ports	4 low noise amplifiers		
Readout Rate			
4 MHz	4 ports x 1 MHz		
1 MHz	4 ports x 250 kHz		
Binning and Windowing	1x1, 2x2, 4x4 and 8x8; Arbitrary sized centered window		
ADC Dynamic Range	16-bit		
Vertical Shift Speed	200 μsec		
Operating Range	15°C to 30°C; 40% to 75% relative humidity (non-condensing)		
PC Interface	USB 2.0		
I/O Triggers	External In, Expose Out, Shutter Out		
Dimensions (H x W x L)	6.0 in. x 5.7 in. x 10.5 in. (152 mm x 145 mm x 266 mm)		
Camera Weight	17 pounds (7.7 kg)		

*Note: All Specifications measured in 1x1 (full image) mode unless stated otherwise. Subject to change without notice.

Mechanical Drawing

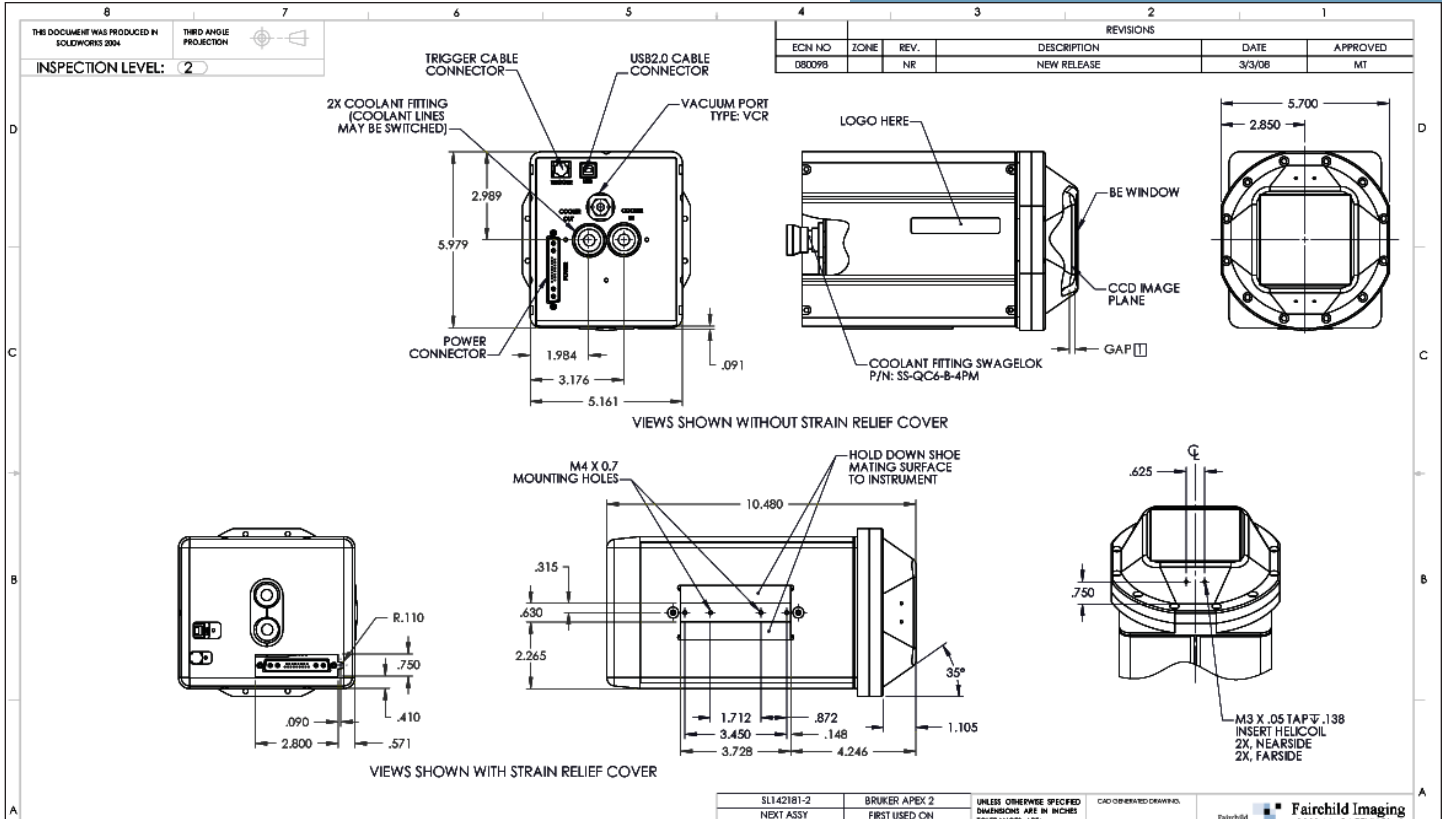

Readout Rates

	1 x 1 - 4MHz	2 x 2 - 2.5 MHz	4 x 4 - 2.1 MHz	8 x 8 - 1.6 MHz
Readout Time	6.5 sec	1.90 sec	1.18 sec	0.55 sec
Frame Rate	0.15 fps	0.52 fps	0.85 fps	1.8 fps

Note: Measured with 0 sec exposure. Actual results may vary depending upon your experimental conditions.

Sensitivity Curve

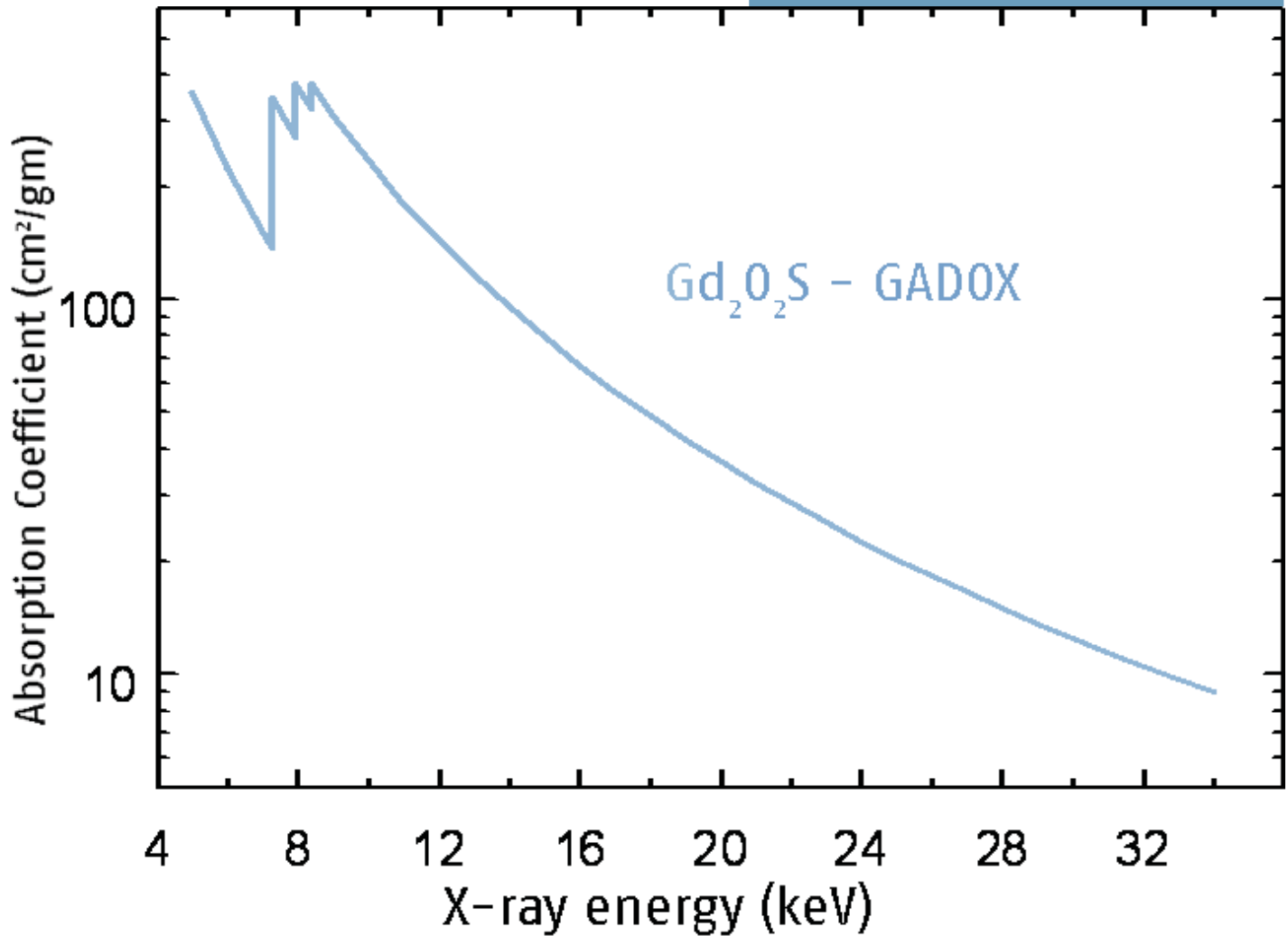

Fairchild Imaging certifies that its products are fully inspected and tested at the factory prior to shipment, and that they conform to the stated specifications.

This product is designed, manufactured, and distributed utilizing the ISO 9001:2008 Business Management System.