

Fairchild Imaging SciMOS 2051 F2

5.5MP Scientific CMOS Camera

PRODUCT DESCRIPTION

The SciMOS 2051 is a high performance scientific CMOS (sCMOS) camera intended for OEM imaging systems requiring high resolution, speed, sensitivity, and dynamic range. This scientific camera features a 5.5 mega-pixel, 4/3 inch type, sCMOS sensor delivering real-time full resolution data at 100 frames per second (fps). Using pre-defined region-of-interest readout modes offers even higher speeds. The ultra-low noise sCMOS sensor combined with a built-in Peltier cooler ensures that noise is negligible in this high-speed high-resolution camera. With less than two electrons total noise and quantum efficiency above 55%, the SciMOS 2051 is truly a breakthrough in scientific imaging and is the ideal candidate for such demanding low-light imaging applications as Next Generation Sequencing, FRET Imaging, 3D/4D Fluorescence Microscopy, and High Content Screening. This OEM camera boasts a compact design and your choice of C-mount or F-mount lens interface to ensure an easy fit in nearly any instrumentation.



FEATURES	BENEFITS
2560 x 2160 pixels, 6.5 μm pitch	High resolution (5.5 Megapixels)
16.6mm x 14.0mm active area	Large FOV fills typical microscope apertures
<2 e- rms readout noise	Scientific precision low noise measurement
Thermo-electric temperature stabilized	Negligible dark current
> 55% peak QE at 550nm	High sensitivity for photon starved applications
16 bit output	High dynamic range
Full Camera Link® Interface	Reliable, high speed data transfer
Compact design	Easy OEM integration

SPECIFICATIONS

SPECIFICATIONS ¹			
Sensor Type	CIS2051, front illuminated, scientific CMOS (sCMOS) image sensor		
Resolution	2560 x 2160 pixels		
Pixel Size	6.5 μm x 6.5 μm		
Image Area	16.6 mm x 14.0 mm		
	Minimum	Typical	Maximum
Read Noise ²		1.2 e-	2 e-
Full Well Capacity	30 ke-		35 ke-
Gain		1.6 DN/e-	
Linearity			2%
Dark Current (25°C)			25 e-/pix/sec
Cooling	Precision Temperature Control; operates at 25°C \pm 0.1°C in 22 – 28°C environment		
Maximum Frame Rate ³	16 bit Data	8 bit Data	
2560 x 2160	74 fps	100 fps	
2048 x 2048	94 fps	105 fps	
1920 x 1080 (HDTV)	189 fps	200 fps	
Data Throughput ⁴			
8 bit mode	850 Mpixels/sec		
16 bit mode	425 Mpixels/sec		
Binning	2x2, 4x4, 8x8 (digital binning)		
Data Range	16 – bit max		
Operating Environment	Temperature range is 15°C to 30°C; humidity range 20 – 80% in 20°C ambient environment		
I/O Interface	Full Camera Link®, Mini SDR connector		
Lens Adaptor	F-mount or G mount options		
Dimensions ⁵ (H x W x L)	3.46 in. X 3.46 in. x 5.94 in. (88mm x 88mm x 151)		
Camera Weight ⁵	2.7 lb (1225g)		
SciMOS SDK	Windows 7,32 and 64 bit support RedHat Linux version 5.5 support		

Notes:

1. Specifications subject to change without notice.
2. Median value of the read noise distribution.
3. Frame rates for uncompressed, 16 bit and 8 bit images on 64 bit Windows 7 based system under free-running operation. Requires the use of a BitFlow Karbon CL4 SP frame grabble for full speed performance.
4. Sustained throughput for uncompressed images. Length of data collection limited only by available RAM (up to 190 GB for 64 bit Windows 7)
5. Camera dimensions and weight are nominal and neglect optional lens mount

The Automated Imaging Association (AIA), as sponsor of the Camera Link committee, owns the US trademark registration for Camera Link.

QUANTUM EFFICIENCY

QE curve

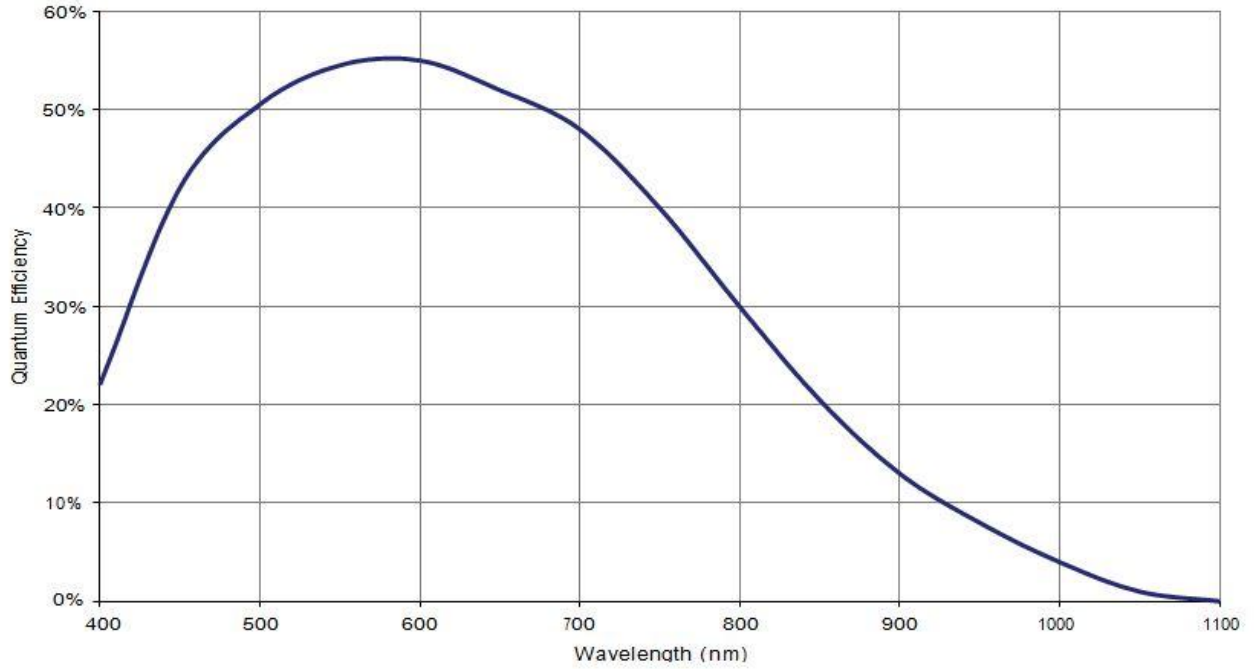

MECHANICAL INTERFACE

C-mount shown

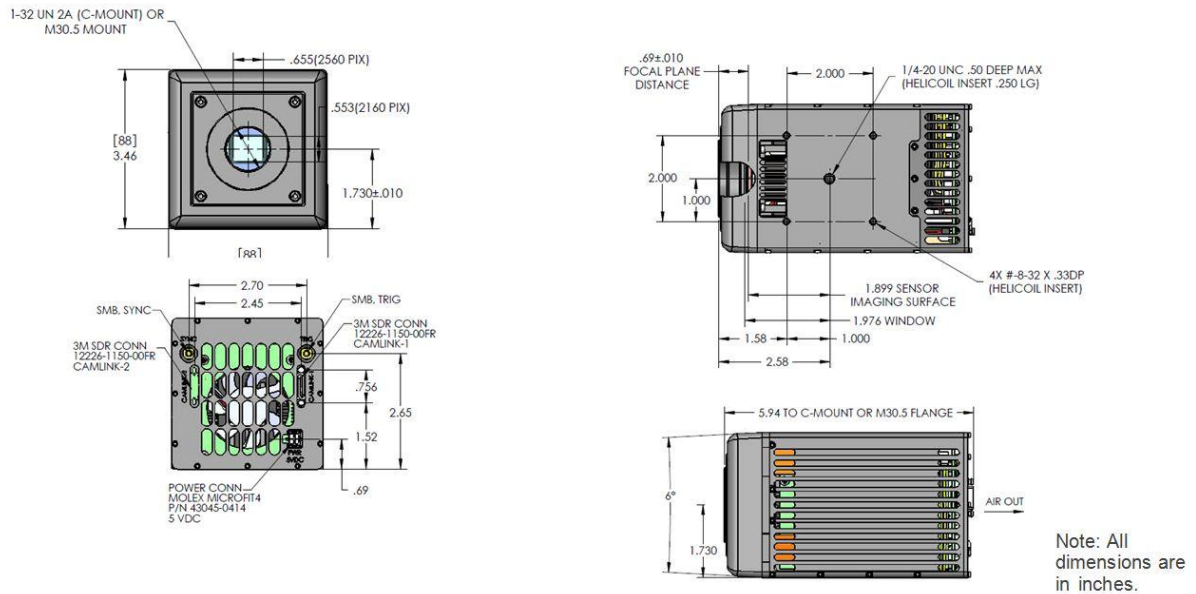

WARRANTY AND CERTIFICATION

Within twelve months of delivery to the original customer, BAE Systems Imaging Solutions will repair or replace, at our option, any Fairchild Imaging components or camera products, if any part is found to be defective in materials or workmanship. Contact Customer Service for assignment of warranty return number and shipping instructions to ensure prompt repair or replacement.

BAE Systems Imaging Solutions certifies that its Fairchild Imaging products are fully inspected and tested at the factory prior to shipment, and that they conform to the stated specifications.

FOR MORE INFORMATION, CONTACT:

BAE Systems Imaging Solutions
1801 McCarthy Blvd.
Milpitas, CA 95035 USA
Telephone 800 325 6975
Fax 408 435 7352
www.fairchildimaging.com

This product is designed, manufactured, and distributed utilizing the ISO 9001:2008 Business Management System.

©2011 BAE Systems Imaging Solutions reserves the right to make changes to its products and/or their specifications at any time without notice.